

BL搅拌缸提升机

Bowl Lift for Spiral Mixers

产能：可达600公斤
Capacity: Up to 600 kg



Sveba-Dahlen BL系列提升机是将面团提升、倒入料斗、分块机及其他类似装置，坚固耐用。提升的重量可达600公斤（包括搅拌缸和面团），提升速度为5米/分钟。

Sveba-Dahlen BL is a solid bowl lift for lifting and tipping dough into a bulk hopper, a divider or similar applications. The lifting capacity is up to 600 kg (bowl and dough) with a lifting speed of 5 meters per minute.

产品特点和优势

- 提升速度5米/分钟
- 标准提升高度可达3米
- 带有安全开关和急停开关的安全罩
- 两个电机驱动两个独立的链条
- 可向左或向右倾倒

选项

- 提升高度可达4.2米
- 电箱可安装于墙壁
- 垂直向前倾倒
- 用于使用其他厂家的搅拌缸



带有安全开关的安全罩
Safety guard with safety switch



上升和下降及急停均有按钮控制
Push buttons for up/down movements and emergency stop

FEATURES AND BENEFITS

- Lifting speed of 5 meters/minute
- Standard lifting height up to 3 m
- Safety guard with safety switch and emergency stop
- Two gear motors lifts the bowl by two separate chains
- Tipping left or right as standard

OPTIONS

- Lifting height up to 4.2 m
- Electrical cabinet for wall mount
- Straight forward tipping
- Designed for bowls from other manufacturers

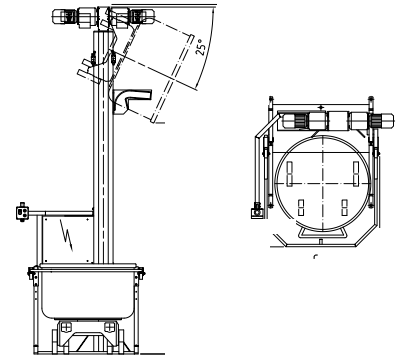

技术参数 SPECIFICATIONS

	BL-LOW	BL-HIGH
高度可达 MAX TOTAL HEIGHT	3040 mm 3040 mm	4250 mm 4250 mm
提升重量可达(包括搅拌缸及面团重量) LIFTING CAPACITY (INCLUDING BOWL)	600 KG 600 KG	600 KG 600 KG
提升速度(米/分钟) LIFT SPEED (M / MIN)	5米/分钟 5M / MIN	5米/分钟 5M / MIN
倾倒方向 TIPPING	左 / 右 / 前 ¹ LEFT, RIGHT, FORWARD ¹	左 / 右 / 前 ¹ LEFT, RIGHT, FORWARD ¹
功率 EL LOAD	400V 3P 1.1KW, 3.2AMP 400V 3P 1.1KW, 3.2AMP	400V 3P 1.1KW, 3.2AMP 400V 3P 1.1KW, 3.2AMP

¹ 向前倾倒是一个选项 STRAIGHT FORWARD TIPPING IS AN OPTION

Better baking business.

A Member of the Sveba-Dahlen Group AB